

Rover A SMART

NC processing centre



 **BIESSE**

When competitiveness
means being able to
meet every request

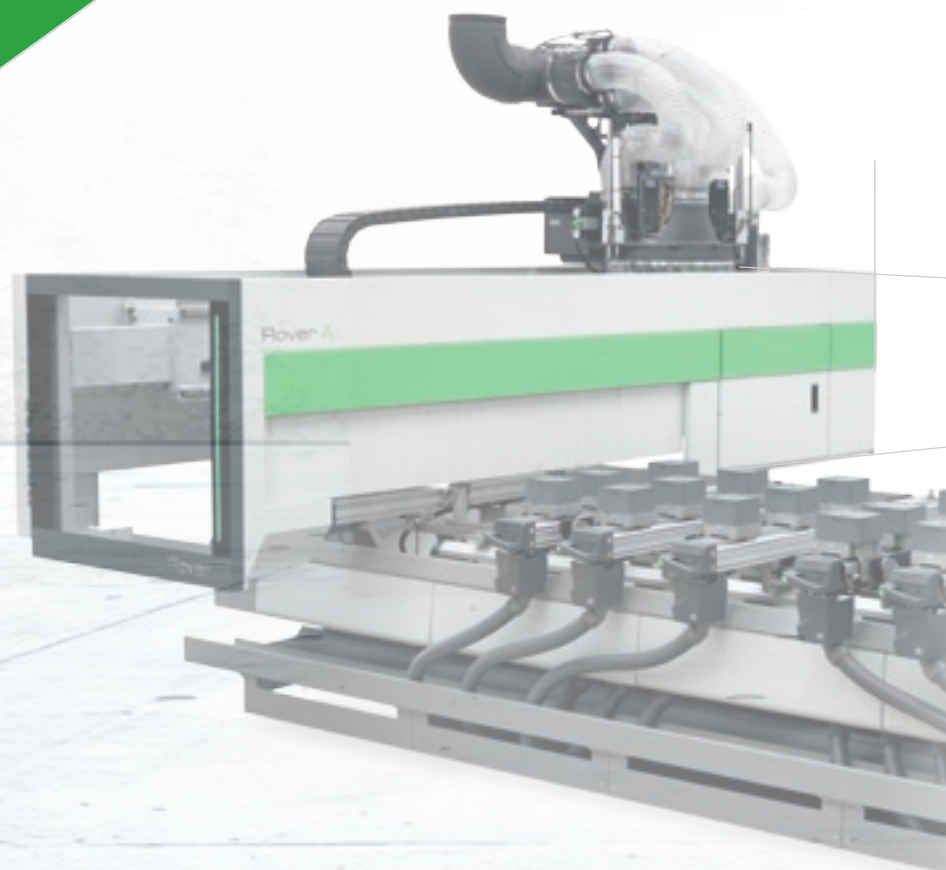

Made **in** Biesse

The market demands

a change in manufacturing processes, enabling companies to **accept the largest possible number of orders**. This is coupled with the need to maintain high quality standards and product customisation with quick and defined delivery times, as well as responding to the needs of the most creative architects.

Biesse meets these requirements

with **technological solutions** that enhance and support technical expertise as well as process and material knowledge. **Rover A Smart** is a simple, user-friendly 5-axis NC processing centre for producing any type of furnishing item. It's ideally suited to both small and large joineries that need to manufacture either irregular shaped components or standard-size components in small batches.

- ✓ **Optimum precision and high finish quality.**
- ✓ **Ability to process large sizes.**
- ✓ **Reduced tool changeover time.**
- ✓ **High-tech becomes accessible and intuitive.**

A choice
for the future



Rover A SMART
NC processing centre

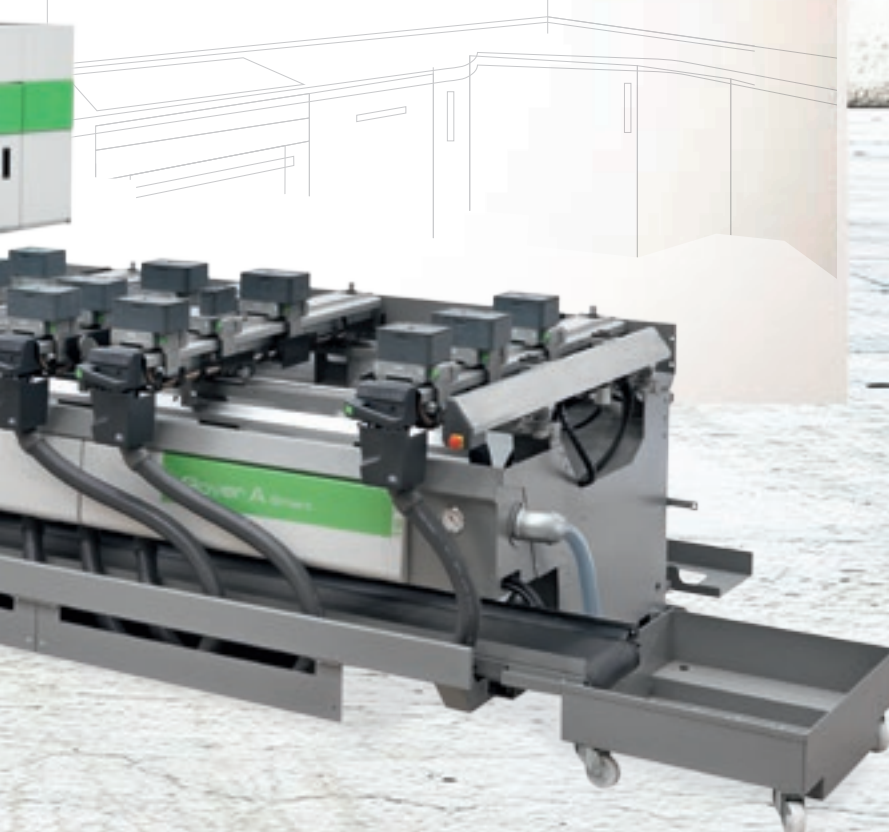

A single processing centre to meet every production need

5-axis technology to give extra value to the finished product.

Allows complex pieces to be created with the utmost simplicity, accuracy and finish quality.





Optimum precision and high finish quality

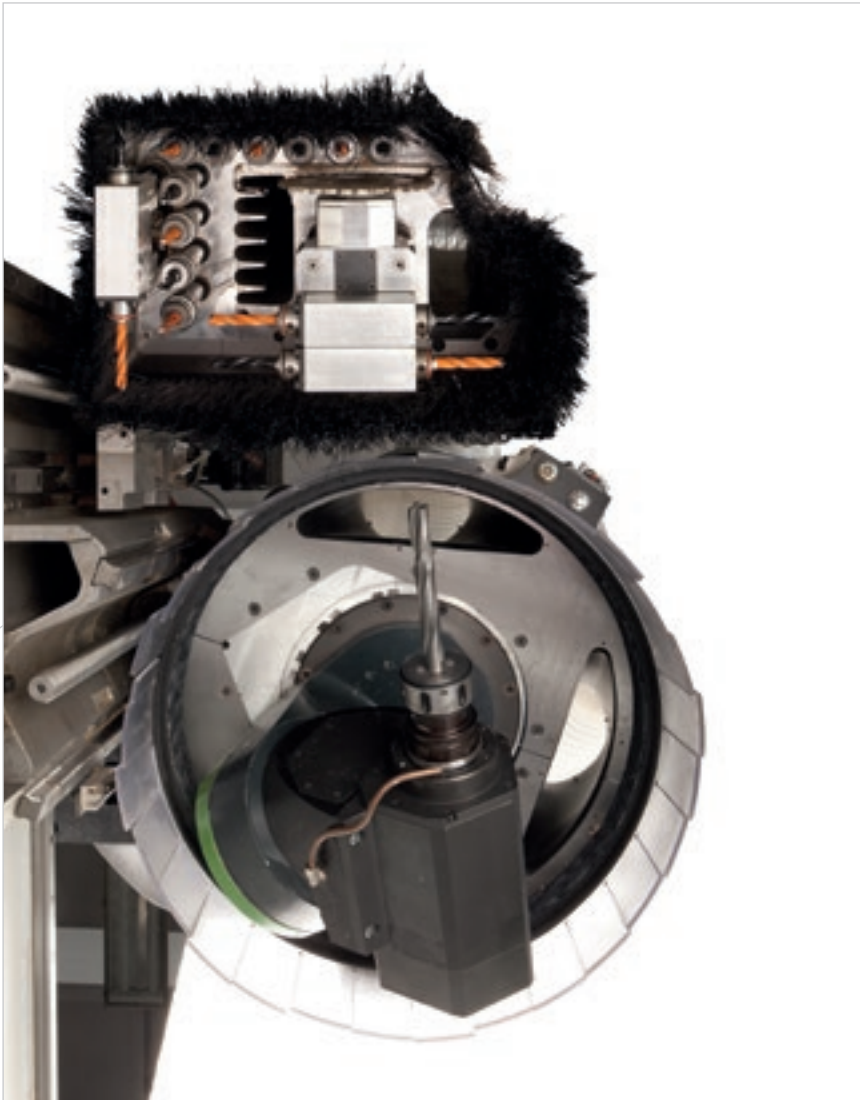

Maximum reliability and productivity thanks to the use of first class components on all the machines of the Rover range.

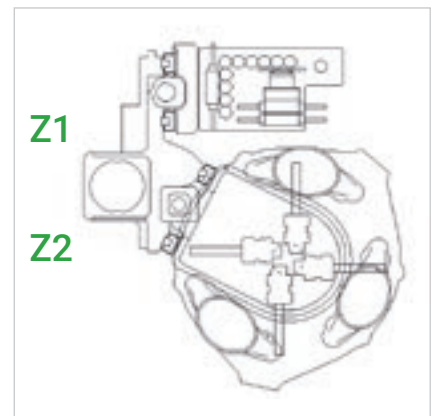

The two independent Z axes guarantee excellent machinability in Z.

The high speed of the Z axis (30m/min) allows the 5-axis unit to perform machining cycles and tool changes very quickly.

Linear slide guides for the work table, for perfect positioning accuracy and stability.

- ✓ 13 kW of power, even at just 12,000 rpm, with "endless" A and C axis rotation to avoid restarts on the piece.
- ✓ Adjustable suction hood (12 positions)
- ✓ A sensor checks the vibrations induced by the tool.

BHZ 17 L
17 tools with rotation up to 6,000 rpm - can be adjusted via the inverter for top boring quality and precision.

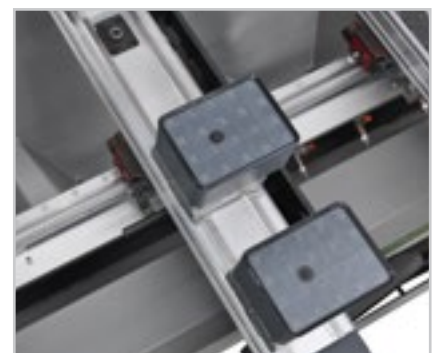

Ability to process large sizes

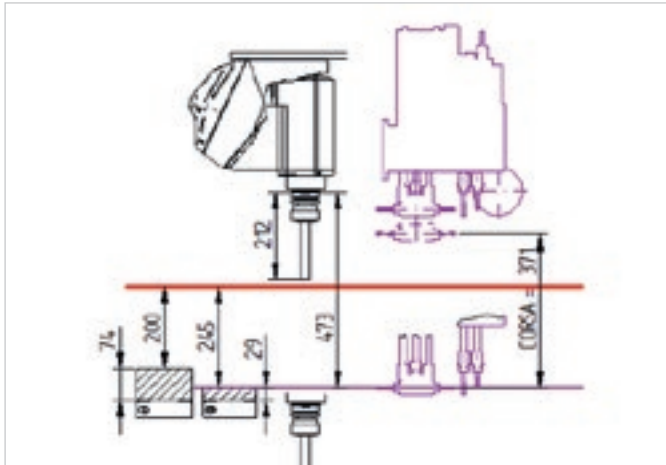

The machine can accept pieces of 245mm (the only one in its category to do so), so every job order can be accepted and pieces of considerable thickness can be machined.



The possibility to load panels with a depth of 1900mm means the pre-sectioning phase can be avoided and pieces larger than the working area can be machined thanks to double positioning.

Reduced tool changeover time

The Biesse work table guarantees an optimum hold on the piece and quick, easy tooling.



Uniclamp
Pneumatic locking systems with quick release.



SA (Set Up Assistance)

The work table has a guided positioning function, providing the operator with suggestions on how to position the panel (indicating the position of the work tables and locking systems) and protecting the working area from the risk of collision with the tool.



16-place Revolver tool magazine on the X carriage, so that tools and aggregates are always readily available. Equipped with a protective tool cover with automatic opening.



12-place tool magazine on the base

The tooling of the 16-place quick Revolver magazine can be automatically modified by picking up the tools from the 12-place rack magazine. This means machining can continue without hampering pendular operation. The first front position acts as a Pick-Up for tooling the Revolver magazine. Equipped with a protective tool cover with automatic opening.

Reduced cleaning times to ensure maximum productivity



↙
5-axis milling unit
with 360mm hood
with adjustable height.



Motorised conveyor belt for the removal of chips and waste.



Integrated deflector (chip conveyor)
managed via the NC.



↙
Chip collection basin supplied with the
chip mat.

User-friendly technology

The 5-axis operating head, equipped with 13 kW HSD spindle and with 360° continuous rotation on the vertical and horizontal axes, enables the machining of complex-shapes ensuring quality, precision and absolute long term reliability.

5 AXES

The high technological content of the world's most popular machining centres, meets the requirements of wood industry professionals. A perfect combination of Biesse innovation and Italian genius.



Practical design

The transparent polycarbonate reinforced protection door is designed to guarantee maximum visibility for the operator. Fitted with 5-colour LEDs indicating machine status, it ensures that processing phases can be easily and safely monitored.

BIESSE IDENTITY

An innovative yet simple design is the hallmark of Biesse's distinctive identity. The perfect combination of Italian genius and taste.

ROVER

High-tech becomes accessible and intuitive



bSolid is a 3D cad cam software program that supports the performance of any machining operation thanks to vertical modules designed for specific manufacturing processes.

- ✓ **Planning in just a few clicks, with endless possibilities.**
- ✓ **Simulating machining operations to visualise the piece ahead of manufacturing and have some guidance for the planning phase.**
- ✓ **Virtual prototyping of the piece to avoid collisions and ensure optimal machine equipment.**

Watch the **bSolid** ad at: youtube.com/biessegrou



bSolid

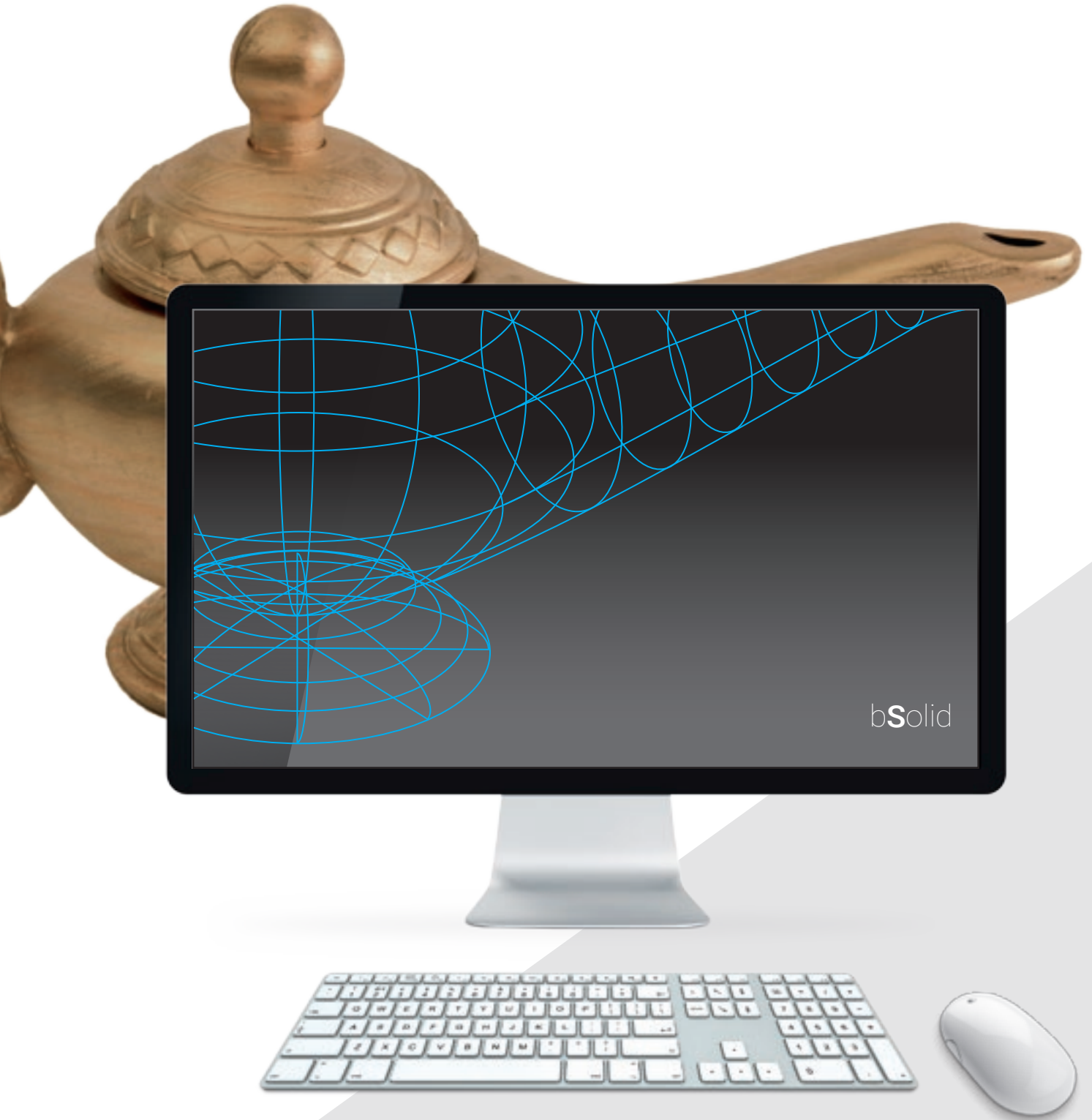

Maximum operator safety

Excellent productivity with high machining speeds, whilst ensuring absolute safety for the operator.



Maximum visibility of machining operation. **LED bar with 5 colours** showing machine status in real time.



Remote control panel for direct and immediate operator control.



Pressure-sensitive floor mats enable the machine to operate at constant maximum speed.



Side curtain guards to protect the working unit; they can be moved to enable the machine to work at maximum speed in total safety.

Vectorial speed of 100m/min.

Technical specifications

Configuration 1

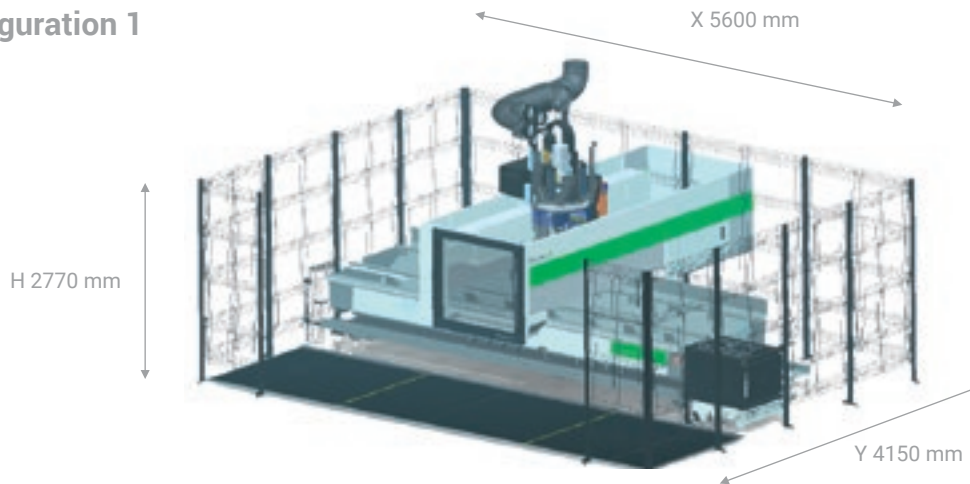

Configuration 2

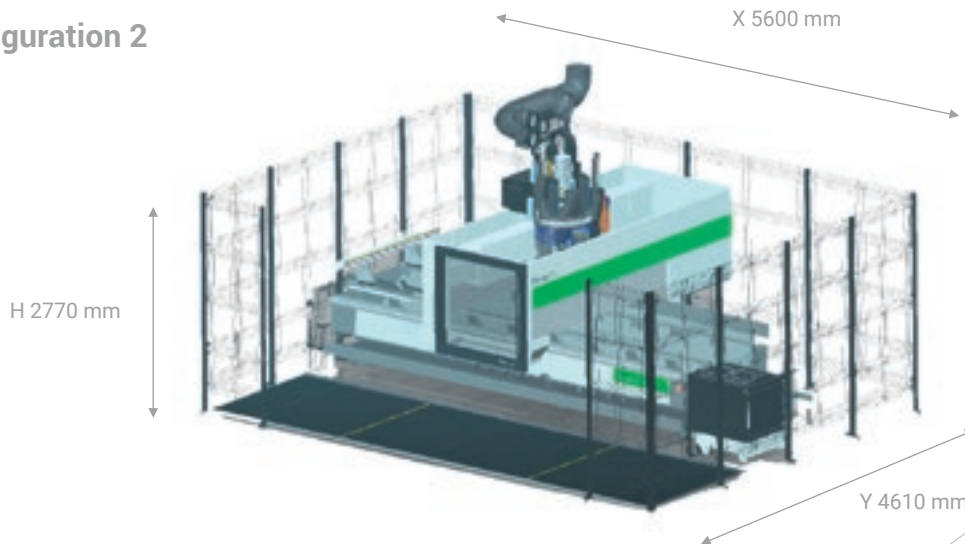

Working fields

	X	Y	Z
	mm	mm	mm
Rover A Smart 1632mm	3280	1620	200/245

The technical specifications and drawings are non-binding. Some photos may show machines equipped with optional features. Biesse Spa reserves the right to carry out modifications without prior notice.

A weighted sound pressure level (LpA) during machining for operator workstation on vane-pump machine Lpa=79dB(A) Lwa=96dB(A) A-weighted sound-pressure level (LpA) for operator workstation and sound power level (LwA) during machining on cam-pump machine Lwa=83dB(A) Lwa=100dB(A) K measurement uncertainty dB(A) 4

The measurement was carried out in compliance with UNI EN 848-3:2007, UNI EN ISO 3746: 2009 (sound power) and UNI EN ISO 11202: 2009 (sound pressure levels at workstation) during panel machining. The noise levels shown are emission levels and do not necessarily correspond to safe operation levels. Despite the fact that there is a relationship between emission and exposure levels, this may not be used in a reliable manner to establish whether further measures need to be taken. The factors determining the exposure level for the workforce include length of exposure, work environment characteristics, other sources of dust and noise, etc. i.e. the number of other adjoining machines and processes. At any rate, the above information will enable the operator to better evaluate dangers and risks.

Service & Parts

Direct, seamless co-ordination of service requests between Service and Parts.
Support for Key Customers by dedicated Biesse personnel, either in-house and/or at the customer's site.

Biesse Service

- ✓ Machine and system installation and commissioning.
- ✓ Training centre dedicated to Biesse Field engineers, subsidiary and dealer personnel; client training directly at client's site.
- ✓ Overhaul, upgrade, repair and maintenance.
- ✓ Remote troubleshooting and diagnostics.
- ✓ Software upgrade.

500 / Biesse Field engineers in Italy and worldwide.

50 / Biesse engineers manning a Teleservice Centre.

550 / Certified Dealer engineers.

120 / Training courses in a variety of languages every year.

The Biesse Group promotes, nurtures and develops close and constructive relationships with customers in order to better understand their needs and improve its products and after-sales service through two dedicated areas: Biesse Service and Biesse Parts.

With its global network and highly specialised team, it offers technical service and machine/component spares anywhere in the world on-site and 24/7 on-line.



Biesse Parts

- ✓ Original Biesse spares and spare kits customised for different machine models.
- ✓ Spare part identification support.
- ✓ Offices of DHL, UPS and GLS logistics partners located within the Biesse spare part warehouse, with multiple daily pick-ups.
- ✓ Order fulfilment time optimised thanks to a global distribution network with de-localised, automated warehouses.

87% / of downtime machine orders fulfilled within 24 hours.

95% / of orders delivered in full on time.

100 / spare part staff in Italy and worldwide.

500 / orders processed every day.

Made **With** Biesse

Biesse Group technologies join forces with Lago's innovation and total quality management processes.

In the crowded world of domestic design, Lago takes its place as an emerging brand, thanks to a collection of stimulating products and a corporate philosophy that embraces the interaction between business and art, coupled with on-going research into sustainable development. "We created a number of projects, or rather, concepts - states Daniele Lago - that have shaped Lago as we see it today: we saw design as a cultural vision that applies not only to individual products, but rather to the entire business chain".

"Flexibility is the key word here at Lago" says Carlo Bertacco, Manufacturing Manager. "We started to introduce the concept of processing only outstanding

orders, which enabled us to reduce our footprint and empty the site from the very beginning".

"The machinery that we purchased - states Bertacco - is great, it entailed a limited investment versus the capabilities it offers and is linked to a specific manufacturing approach. What I am talking about is a given manufacturing volume with Lago-standard quality levels and the possibility of customising as late as possible, at the customer's request: in short, the very basic principles of lean manufacturing".

*Source: IDM Industria del Mobile
Lago, our customer since 1999, is one of most prestigious Italian furniture brands in the world.*

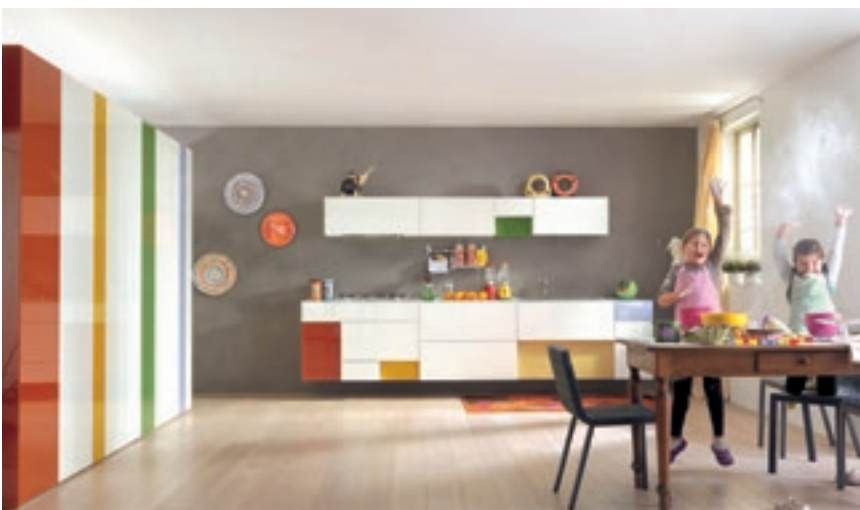

<http://www.lago.it>



Biesse Group

In

1 industrial group, 4 divisions
and 8 production sites.

How

€ 14 million p/a in R&D and 200 patents registered.

Where

34 branches and 300 agents/selected dealers.

With

customers in 120 countries (manufacturers of furniture,
design items and door/window frames, producers of ele-
ments for the building, nautical and aerospace industries).

We

3,200 employees throughout the world.

Biesse Group is a multinational leader in the
technology for processing wood, glass, stone, plastic
and metal.

Founded in Pesaro in 1969, by Giancarlo Selci, the
company has been listed on the Stock Exchange
(STAR segment) since June 2001.

 **BIESSEGROUP**

 **BIESSE**

 **INTERMAC**

 **DIAMUT**

MECHATRONICS

